



USCPS

U.S. COMPOSITE PIPE SOUTH, LLC



Flowtite

Maintenance Manual



AMIANIT PIPE SYSTEMS

01	1 Introduction _____	3
02	2 Symbols _____	3
03	3 Repair of Defects in Straight Pipe Section _____	4
	3.1 Straight Pipeline Section with External Coupler	4
	3.2 Straight Pipeline Section with Butt and Strap Joints	5
	3.3 Straight Pipeline Section with Flange Connection	6
04	4 Repairs of Defects in Fittings and Joints _____	8
	4.1 With External Mechanical Couplers	8
	4.2 With Butt and Strap Joints	8
	4.3 With Flanged Connections	8
05	5 Emergency Repair _____	9
	5.1 Emergency Repair by Means of Laminating	9
	5.2 Emergency Repair by Means of Cementing a Pipe Segment	9
	5.3 Emergency Repair by Means of Clamps	10
	5.4 Draining of Pipelines	10
06	6 Cutting _____	11
app. A	Appendix A Lamination Joints on GRP Piping _____	12
app. B	Appendix B Mechanical Repair _____	17
app. C	Appendix C Pipe wall Liner Repair _____	18

1 Introduction

The following document is intended to be used as a guideline for the maintenance and repair of Fibreglass pipelines. Different repair methods are described in the following pages and the contractor should choose what best fits his site conditions. It is recommended that a small quantity of spare parts be available to minimize the downtime.

2 Symbols

The different joining methods are represented by the following symbols:



Figure 2-1 External Mechanical Coupling

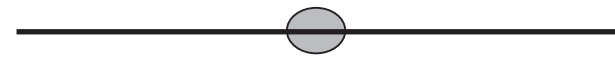

Figure 2-2 Butt and Strap Joint



Figure 2-3 Flanged Joint
(G=Grooved face, F=Flat face)



Figure 2-4 GRP Standard Coupling



Figure 2-5 Leaking Point

! Note: Flat face Flange to flat face Flange is also possible.

3 Repair of Defects in the Straight Pipe Section

01

02

03

04

05

06

07

app. A

app. B

app. C

All pipes and fittings should be inspected before installation at job site to ensure that no damage has occurred during transit or storage.

If leakage appears after installation or during operation of the system, it can be repaired appropriate to the type of joint. Leakage in a straight pipe can be caused during digging or by falling objects.

If existing pipelines are damaged, they can start leaking and therefore the damaged part should be removed from the system. It is advisable to replace the pipe over a distance of $\pm 1/2 W$ (m) on both sides of the damaged part. The length depends on the diameter for the determination of W (m), see **Table 1**.

Several repair methods are described for the different joining systems applied in the pipeline system, starting from the principle of standard lengths of pipe. A combination of the different joining techniques is also possible for repairs.

ID (mm)	W
80 (3") - 600 (24")	1.0 (40")
700 (28") - 1200 (48")	1.5 (60")
Above 1200 (48")	3.0 (120")

Table 1 Length of the piece of repair W

If the described procedures cannot be followed because of a lack of time, a temporary repair by means of a butt and strap joint can be executed as described in section 3.2.

3.1 Straight Pipeline Section with External Coupler

3.1.1 Mechanical Coupler

Schematically the repair method can be represented as follows:

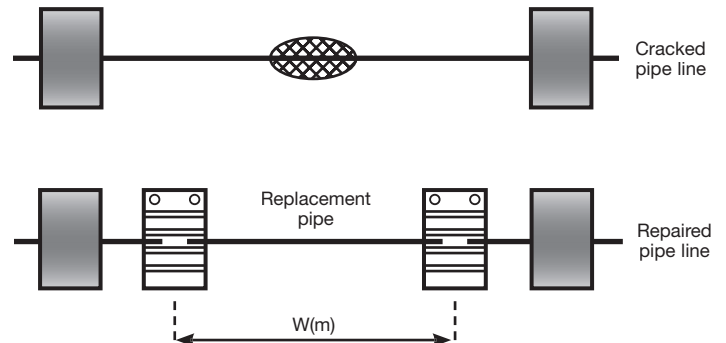

Figure 3-1

If a pipeline system provided with external coupler leaks, a piece of at least $W(m)$ must be replaced ($0.5xW$ on both sides of the leak). Cut a section of the pipe to a length equal to W and examine the ends of the still installed pipe. One possible way to reconnect the system is to use mechanical couplers such as Straub coupling (preferred system), Dresser and others.

For this method the external mechanical couplers can be moved over the pipe. The three parts now available (pipeline parts and repair part) can be replaced in the system by means of two new mechanical couplers. If the coupler itself leaks, it must be dismantled and carefully inspected for cracks in the rubber sealing.

If there are cracks in the coupler it must be replaced. The connection could also be done using butt and wrap joints as described in the sections below.

Refer to Appendix B for more information on mechanical couplers.

3.1.2 With GRP Coupler

This procedure is applicable to GRP unrestrained underground pipelines.

3.1.3 Introductory Note

If a pipe line system provided with coupler leaks, a piece of at least $W(m)$ must be replaced. Remove the damage piece and examine the ends of the still installed pipe. If both are plain ended, go to section 3.1.4 → and use mechanical coupler, or use field lathe machines when available and go to section 3.1.4 →.

3.1.4 Placement of Pipe and Closure

Step 1 Carefully measure the space where the closure pipe is to be placed. The closure piece should be 10-20mm (0.4"-0.8") shorter than the length of the space. The narrower the gap, the easier it will be to make the closure.

Step 2 Use a special pipe with long machined ends ordered or prepared specifically for this purpose. The use of a piece of pipe from an adjustment pipe is recommended.

Step 3 Use two couplings without centre registers, two wide-type flexible steel couplings.

Step 4 Pull the couplings onto the machined ends of the closure pipe after sufficiently lubricating the ends and the rubber ring. It may be necessary to gently help the second ring over the chamfered end of the pipe.

Step 5 Lubricate well the ends of the two adjacent pipes after they are cleaned thoroughly.

Step 6 Place the closure pipe in its final position and pull the coupling over the adjacent pipes up to the home line.

This can be represented schematically as shown in figure 3-1-2 below.

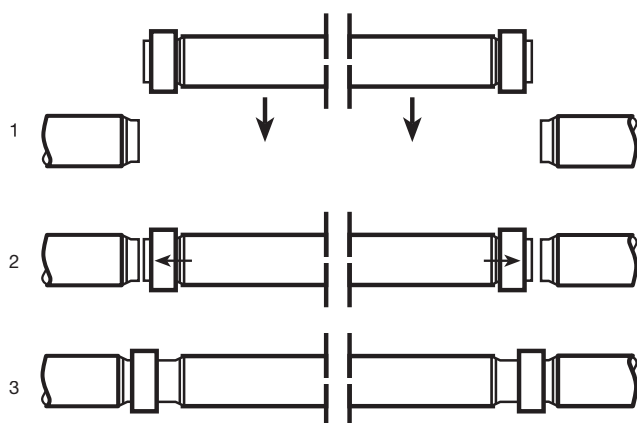

Figure 3-1-2: Closure piece

! Caution: When pulling the couplings over the insertion piece, it is necessary to pull the second rubber ring smoothly over the chamfer of the pipe to avoid damaging it. For that purpose use plenty of the approved lubricants. To locate a fitting exactly, it is recommended to place it at the required position, to assemble the first pipe in full length and then to make a closure as indicated above.

3.2 Straight Pipeline Section with Butt and Strap Joints

Repair of leakage in a straight pipeline section, which are part of a pipeline system with butt and strap joints, is basically executed in the same way as the repair of a pipeline section provided with external mechanical couplers.

The pipe is to be cut at a distance of $0.5 W(m)$ on both sides of the leak. The ends of cut pipe and the replacing part have to be prepared in order to make a butt and strap joint.

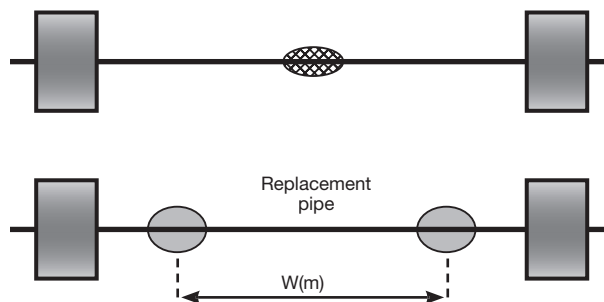

Figure 3-2 Schematic representation of the repair procedure

With this method of repair, it is of great importance to cut the replacement pipe as precisely as possible, whereby the squareness of the cut is decisive.

The width of the gap between the pipe parts is decisive for the reliability of the joint. Before starting the repair procedure, ensure that the pipe is dry and no fluid can get near the section to be laminated.

If leakage occurs in a laminated joint, this part has to be removed and replaced by an adapter using the same procedure as described above.

3.3 Straight Pipeline Section with Flange Connection

Leakage in pipe systems with flange connections can also occur as described above in the connection itself, as well as in the pipe part on which these flanges are joined. Wrong torque of the bolts can cause leakage of the flange connection. The torques applied on the flanges should not exceed the recommended values.

3.3.1 General requirement

Assembly of large diameter flanges with rubber “O” ring seals

GRP flanges are supplied with a groove in the flange face for sealing using an “O” ring gasket. The following assembly instructions are apply.

! Note: When assembling two flanges, only one flange must have an “O” ring groove. The other mating flange must be flat faced.

! Note: “O” rings like all rubber products should be stored in a cool, shaded area away from sun light.

Step 1 Clean the “O” ring groove with a hard brush to remove all dirt and sand, then wipe clean with a damp cloth.

Step 2 Clean the “O” ring with a damp cloth and thoroughly check the ring for cracks by stretching the gasket all around to about 30% over its normal length. Never used cracked or otherwise damaged “O” ring gaskets.

Step 3 Insert the “O” ring in the flange groove and secure in position using several small strips of double sided adhesive tape placed between the “O” ring and the groove surface.

Step 4 Align the two flanges and insert the bolts, nuts and washers after cleaning and lubricating.

Step 5 Tighten the nuts and bolts using a torque wrench following the sequence to a torque of 25lb-ft (35Nm).

Step 6 Re-torque all nuts and bolts in the correct sequence to 45lb-ft (65Nm). This torque is normally sufficient to achieve the required sealing during the hydrostatic test and normal operation. Maximum torques must not exceed 75lb-ft (110Nm).

! Important Note: If there is a need to change the flange, a cut in the pipe should be made and the new flange has to be connected to the equipment first so that no torsion is applied on the flange. After this connection, the butt and strap joint can be made between the existing pipe and the new flange.

Assembly and disassembly of flanged equipment

When assembling flanged parts (equipment, valves, orifice flanges etc.) one must bear in mind that these parts may need to be disassembled in the future. To provide space for disassembly in any installation, there must be a mechanical flange adaptor or a dismantling joint placed between the flanged equipment and the piping on one side. This allows some displacement in the axial direction.

Trouble shooting

If an assembled joint leaks, you need to loosen and remove all bolts, nuts, washers and gaskets. Check for alignment of assembly. Rebuild to correct alignment as required. Check the gasket for damage. If damaged, discard and replace with a new, undamaged gasket. Check flanges for seal rings. Flanges with damaged inner seal rings must be removed and new, undamaged flanges installed. If leaks occur as a result of deficiencies in non-fibreglass components of the pipeline system, consult the manufacturer of the defective components for recommended corrective procedures.

Clean and lubricate old threads and washers before rejoining. Repeat the joining procedure outlined above. After corrective action has been taken, retest the joints to see if a seal has been made.

When using glass fibre-reinforced flanges in a pipeline system, the designer and installer must supervise the installation against flat-faced flanges. When tightening flat-faced glass fibre reinforced flanges against raised-face flanges using the above mentioned torque, the allowable bending stress in the glass fibre reinforced flanges will be overstepped which results in cracking the neck of the flange.

If this procedure is not possible the annular void should be filled with a hard gasket material or a spacer ring.

Tighten all nuts in increments following a diagonal sequence to the required torque as per the Flange Torque Procedure.

After ten minutes any leakage should be stopped.

If the joint is still leaking the gasket has to be removed and replaced by a new one.

3.3.2 Laminated flange connections

A repair of a pipe section with flanges is possible using a butt and strap joint. This procedure is illustrated in **Figure 3-3-1**.

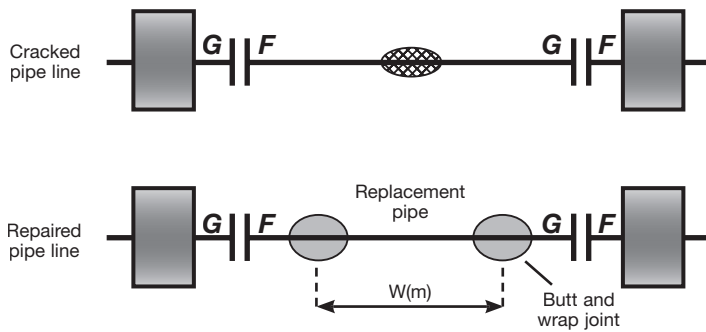

Figure 3-3-1

After dismounting of the flanged pipe section, its length must be measured and a straight line drawn between two facing boltholes. Hereafter the section to be repaired must be cut out of the pipeline over a distance of $0.5 W(m)$ on both sides of the leak.

The adapter with a length $W(m)$ should also be marked with a line parallel to the axis of the pipe. For cutting see chapter 6 [→](#).

Be sure that the marks on the pipe parts are in an even line before laminating. This procedure also can be executed without dismounting the flanges, however there must be enough room for laminating and drying of the pipe line internally and externally.

4 Repair of Defects in Fittings and Joints

Before installation of a fitting it is necessary to inspect it for damage that might occur in transportation and / or storage. In case of doubt do not use the fitting. Ask for manufacturer's advice.

Any of the methods described hereafter can be used for the repair of fittings and joints.

Temporary and emergency repairs can be applied to any type of fittings. A permanent repair can then be made to replace the temporary one.

4.1 Fitting with External Mechanical Couplers

Disassemble the external mechanical couplers to remove the defective fitting to be replaced. These mechanical couplers e.g. (Strap, Taylor Kerr, Viking Johnson, Arpol and Dresser) can be pushed over the ends of the fitting or the connected pipe / fitting.

- Check for cracks in the sealing rubber and replace the coupler if defective.
- The assembly of this type of coupler should be done on a proper cleaned surface; at the same time the seal of the coupler must be cleaned.

4.2 Fitting with Butt and Strap Joints

If leakage occurs in a fitting that is connected to a pipe system by means of butt and strap joints, it is necessary to cut out this fitting next to these joints and replace with a fitting of equal dimensions to the removed part.

For cutting see section 6 [➔](#) and Appendix A [➔](#). Before cutting the dimensions of the part to be repaired have to be measured and drawn, as accuracy of cutting is decisive for the reliability of the joint to be made.

The illustration of this repair method is as follows:

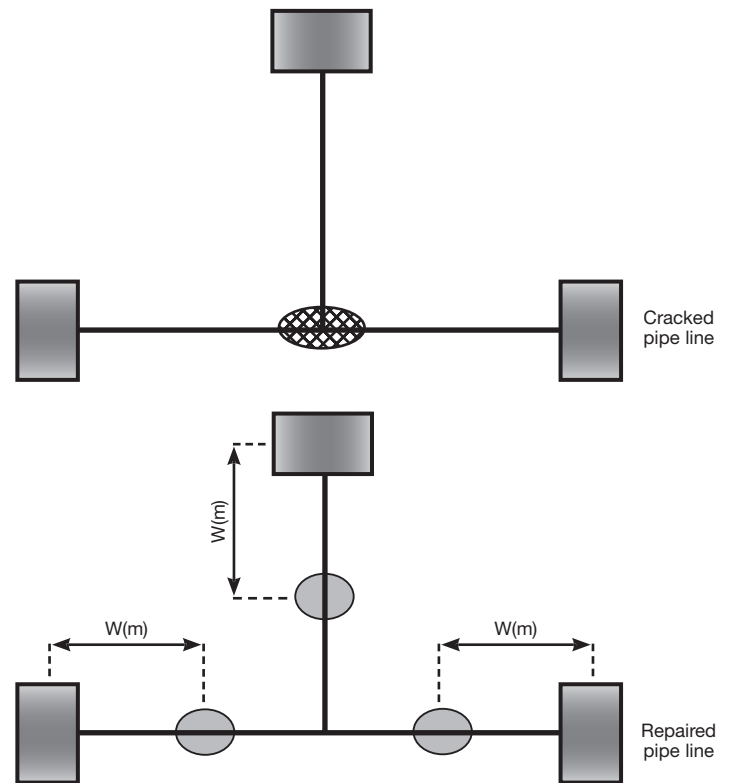

Figure 4-2

4.3 Fittings with Flanged Connections

If leakage occurs in the fittings itself, it should be disassembled and replaced completely. Wrong torque, a leaking gasket, or a fitting that is fitted under tension can cause leakage in the flange connection itself. The bolts of a flange connection should be tightened in increments following a diagonal sequence according to the sequence shown in the Installation manual. After the maximum torque has been applied in accordance with the values in the general requirements mentioned under section 3.3 [➔](#), the leakage should stop within 10 minutes. If the joint still leaks the gasket must be replaced.

5 Emergency Repair

If circumstances mean that a complete repair cannot be made, one may decide to do a temporary repair. Emergency repairs are not always temporary. The evaluation should be made on a case by case basis.

However, the final repair must be executed within a reasonable period of time, at the latest it must be done within 3 months. At the defect the fluid will penetrate into the laminate and might attack the open glass rovings. It could be that the medium to be transported would be forced into the laminate over a great distance, which should be prevented.

5.1 Emergency Repair by Means of Laminating

One of the temporary repair methods is covering the outside of the defect with a laminate. For this purpose the pipeline must be made pressure-less and dried to prevent the laminate from getting wet. If it is not possible to dry the pipe, then it is recommended that the pipe is emptied.

The area of the external layer around the damage should be removed by means of a grinder. This grinding should include the whole laminating area. The ground surface should be dried with a heater, without burning this surface. The resin / hardener mixture should be prepared and the ground surface moistened by means of a roller or brush. Then in turns a layer of glass and a layer of resin mixture should be applied, taking into account that every layer should first be applied after the previous one has been fully impregnated with resin.

- The thickness of the layer to be applied is as per the requirement. Check with the engineering department for the exact dimensions.
- After applying the repair laminate it must be cured.
- After curing has been completed, the pipeline can be pressurized.

For description of the laminating technique see Appendix A [➔](#).

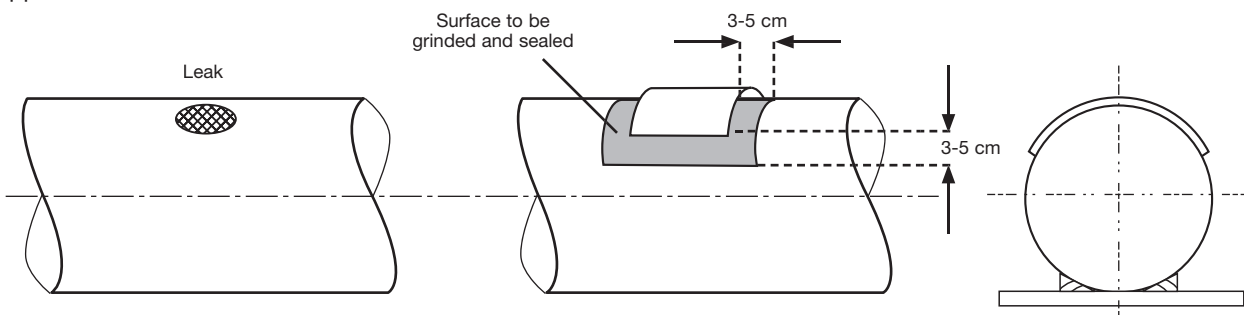

Figure 5-1

5.2 Emergency Repair by Means of Cementing a Pipe Segment

The line should be pressureless before starting the repair procedure.

- 1 Placing the leak in the middle mark on the pipe the dimension of the segment prepared to be used.
- 2 Grind the area and dry it.

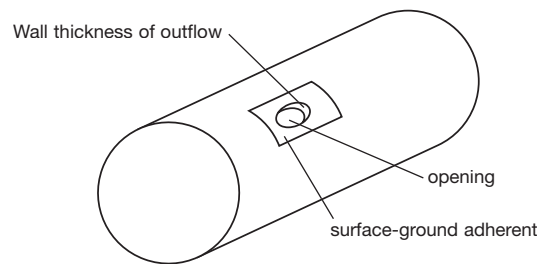

Figure 5-2

- 3 Applying the adhesive: Single component packs (SIKABONT) can be used immediately.
- 4 Apply the adhesive to the whole area of the underside of the saddle and the marked surface of the pipe.
- 5 Position Segment using light pressure. Fix with tensioning belts until completely hardened.

Observe the fixing and curing times in table below.

	Sikabont
Handling time	40 min*
Fixing time	60 min
Working temperatures	+5° to +35°C
Load bearing after:	at 3 mm adhesion gap = 24h

* 23°C; 50% rel. humidity

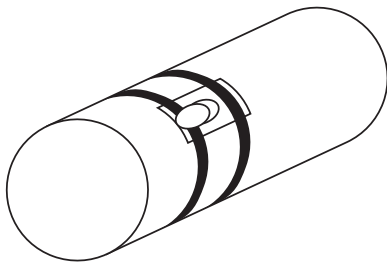

Figure 5-3

- 6** Once the segment is fixed, reach through the opening and seal the remaining gap between pipe and saddle with the remaining adhesive. Also clean and remove any residual adhesive.

Loads must be avoided during the hardening times.

- !** **Note:** In order to make a stronger repair, a lamination joint should be added on the top on the segment. The laminate used must be wider than the standard one as it should cover the entire segment piece and extend to a width equal to the bond length of the joint. Care should be taken to taper the segment at the edges so that no extra stresses are created.

5.3 Emergency Repair by Means of Clamps

A simple method to stop leakage is using rubber lined divisible clamps, which can be mounted over the pipe section to be repaired. Several manufacturers, such as Dresser, George Fischer, Wag, supply repair parts. For small leaks a simple rubber lined clamp, made by the contractor himself, can be used. Once the water stops, a lay-up should be made to cover the clamps. The lay-up should be extended at least 300 mm from each side of the clamp. This method is mostly applicable to full glass pipe systems.

5.4 Draining of Pipelines

For some repair methods it is essential that the pipeline section is completely empty. If it is not possible to close the pipeline with valves and to drain the system, the freezing method can be used.

5.4.1 The freezing method

If the line cannot be partly or completely drained, the „freezing method“ could be used. The leak in the pipe is sealed using a sleeve with liquid nitrogen around the pipe. Freezing time will depend on the size of the pipe.

5.4.2 Stopping dripping

In order to perform a laminating joint, the section should be completely dry. One way to stop dripping is to insert salt before starting the lamination. Salt is a good absorbent.

5.4.3 Other repair materials

- **3M DP-605 (640)**
3M DP-605 can be successfully used to seal and permanently repair leaking sections of pipe after water stop measures have been implemented. DP-605 is a two-part urethane epoxy adhesive that lends itself well to small quantity repair procedures. This product sets in approximately 15 minutes at 75°F. DP-605 is temperature sensitive; therefore, colder temperatures make dispensing very difficult. The DP-605 cartridges should be stored or preheated to room temperature before use. The DP-605 first cures as a flexible material but with time becomes hard, reaching full structural strength after 24 hours. It is available in convenient Duo Pack's that mix the resin with the hardener. DP-605 can be purchased through a local 3M distributor.
- **Avanti 202 Multi Grout**
AV-202 is a polymer solution that cures when reacted with water in any proportion to form a strong film, gel, or foam of polyurethane. AV-202 is used to stop infiltration from groundwater by forming a flexible elastomeric barrier in the area of the application. Alternate grout materials are Scotch Gard 5610 or DeNeflex 44, but these materials do not surface bond as well as the AV-202.

Application procedure

A qualified technician certified in Confined Space Entry should perform any internal repair.

This type of repair is most commonly due to ground water infiltration at the joints. Excavation, dewatering, or chemical grout injection from inside the pipe can stop infiltration.

The grout can be pumped through the wall of the pipe into the saturated embedment where it reacts with the ground water to form an external elastomeric barrier.

The following joint sealing procedure is performed using Avanti AV-202 packaged in a caulk tube cartridge. The procedure may not work in all situations and can be dependent on experience in finding the “sweet spot.”

6 Cutting

Step 1 Pack the area of water infiltration, between the center register and the end of the spigot, with strips of rag or cut lengths of 3mm (1/8") chord. This procedure will slow or stop the flow as to prevent the flushing out of the grout material after injection. The grout must have time to react with the available water.

Step 2 Assemble a grout cartridge with an injection tip into a caulking gun. Snip off the end of the tip.

Step 3 Drill a 6mm (1/4") hole through the spigot wall only, positioned somewhere between the center register and the gasket.

Step 4 Insert the injection tip firmly into the hole and slowly pump in the grout. Continue injection process till refusal or visible grout leakage.

Step 5 Cut a 50mm (2") length of chord or a piece of rag, remove the calk tube cartridge from the hole and poke the rag or chord into the hole using a screw driver. Any barrier will keep the grout in the annular space till it has time to react with the available water to form a closed cell bonding foam barrier. Internal expansion is significant and will displace the free water.

Step 6 Once the infiltration is stopped, the leak may move around the joint and new injection sites may have to be initiated.

Step 7 It is best if the repair can be accomplished from top to bottom as final sealing in the bottom area is easier than overhead.

Step 8 At times, it may be helpful to pack off the joint leaving the bottom open or drilling relief holes in the bottom. The top and sides down to the flow line can then be sealed with epoxy (3M DP-605) and allowed to cure. Then the bottom can be packed off and injected with AV-202 to seal in a final controlled manner.

Step 9 The whole procedure works best if the grout is kept as internal as possible. Grout that is pushed out in small amounts following the leaks is unavoidable. Large grout leakage is wasteful, expensive and creates a great mess as it blooms in the bottom of the pipe.

The cutting of glass fibre reinforced pipes can be done by means of metal saw (for small diameters) or a grinding wheel (diagrit or carborundum).

The pipe section to be cut should be marked off using a marker along a pipe wrap-around after which the cutting can be done using a hack-saw.

As the reliability of the connection to be made depends on the squareness of the saw cut, it is necessary to pay attention to this operation.

If a pipe should be cut to make a butt and strap joint, the cut end of the pipe may be levelled off. The maximum gap between the pipe sections to be joined is 3 mm. If a spigot end is shaved for a cement joint, the end of the pipe will be bevelled off automatically.

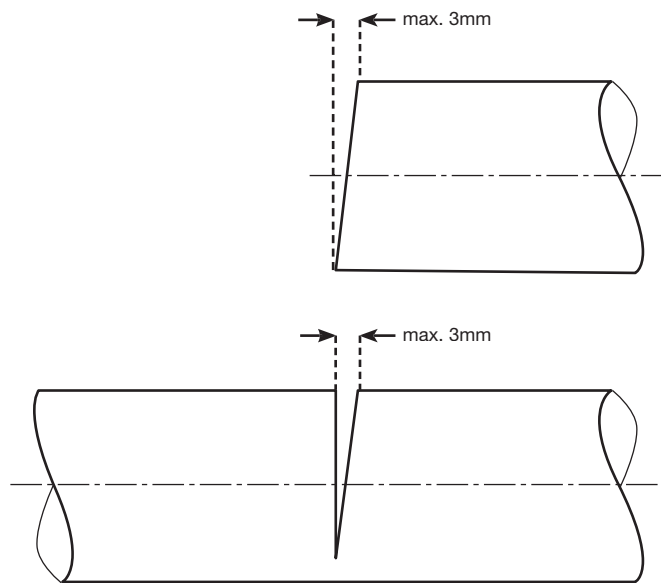

Figure 6-1 Tolerance for cutting

Appendix A

Lamination Joints on GRP Piping

Scope

This procedure covers field lamination joints (lay-up joints) and field laminating an external / internal lay up joint on GRP piping. Ensure that the entire recommendations are read and understood well prior to proceeding with lamination at site. Any deviation in the implemented procedure should be first verified by the manufacturer's Field Service Representative.

Purpose

To provide the basic technical information to the user in order to achieve the requirements without incident.

Materials & Tools

The following material, tools & equipment should be arranged for the lay-up joints:

- Fiberglass joint kit, which includes:
- Glass chopped strand mat with specific dimensions (width / length).
- Glass woven roving with specific dimensions as per diameter.
- Resin (promoted, not catalysed).
- Catalyst / hardener.

The following material, tools & equipment shall be arranged for the lay-up joints:

- Rotary disc grinder with carborundum sanding disc.
- Graduated measuring cylinder for measuring catalyst.
- Paint rollers 50mm in diameter with 15-20cm. Long handle.
- Steel grooved rollers.
- Mixing tongues / sticks.
- Polyethylene empty pots for mixing resin.
- One table per crew, big enough to accommodate largest strip of mat or woven roving.
- Solvent (methylene chloride) for cleaning pipe surfaces prior to lay-up.
- Styrene: For cleaning tools and to bubble-out during lay-up.



Safety Requirements for Crew

Safety goggles, safety shoes, dust masks, safety helmet, safety belts (in case of high elevation).

! Client safety instructions must be strictly followed.

Material Storage

Upon receiving the GRP lamination materials, it is important to store them in proper place.

- **Resin:** Should be stored in shelter. The supplied promoted resin has a maximum life of three months. If not stored properly, it may get hard in a very short period.
- **Catalyst:** Should be stored in a cool maintained room (20 - 25°C)
- **Mat & woven roving:** Should be stored in a closed room to avoid dust, damp and direct sunlight.
- **Styrene:** Should be stored in same condition as resin.
- **The entire storage area must be marked with "NO SMOKING" sign boards.**

Usage of Materials

The promoted resin is used by mixing it with catalyst with an appropriate ratio. This ratio varies as per weathering conditions, the hotter the weather, less the amount of catalyst to be added:

Minimum amount of catalyst required	1% (Hot weather)
Maximum amount of catalyst required	3% (Cold weather)

- Such mixture will become warm through exothermic reaction.
- Mix the catalyst as per the ratio described above and mix it with mixing tongue or use a long, straight, clean wooden stick.
- At this stage, temperature will rise progressively (colour change as well) until it reaches to a peak signifying an end to the reaction.
- This temperature peak is accompanied by a rapid gelling of the materials.
- Gradually it cools to a hard mass.
- The gel time varies depending on the amount of catalyst mixed with resin.

Site Conditions

- Dampness:** The lay up joints must be conducted in dry conditions. Any moisture / dampness on the pipe surface or on the lay up table may lead to a poor bonding of the joints. Therefore, precautions must be taken during humid / wet weather. A portable shelter that covers the pipe jointing area can be used. A portable heat source (high volt bulb) may also be required if weather is continuously humid / wet.
- Hot weather:** As mentioned earlier, the gel time decreases as the atmospheric temperature increases. The gel time becomes very short. It is recommended that adequate ventilation be maintained in the shelter over the pipe.
- Cold weather:** If the temperature at site is too cold, which may increase the curing time of the applied layers, it is recommended that a heated shelter be used. High voltage lamps / hot blowers could be used in the surrounding area, but not directly on the work place.

Pipe Lay-up Joint Procedure

Lay-up joint on GRP piping has two stages:

Stage 1 Grinding the pipe surfaces (internal, external)

- Thoroughly clean the pipe ends that are to be jointed.
- Check the plies width to be applied on to the pipe joint. (Termed as total bond width). Mark on each pipe end a distance of one half the total lay-up width. This marked area is to be ground.
- Use rotary disc grinder / sander to grind the area. This procedure removes the shiny surface of the pipe.
- For diameters 600 mm and above, internal lamination is also required. An internal lamination should include groove at the lamination ends. This grooving should absorb the laminated plies edges into it. These grooves facilitate the product flow without reducing the flow momentum.
- The grinding procedure should be repeated if the prepared surface is contaminated prior to starting the lamination work.



Stage 2 Application of the Lamination layers / plies

- Wipe the ground areas with clean solvent / cloth to remove the collected dust and any surface moisture. The solvent must be allowed to evaporate completely.
- Align the pipe section as perfectly as possible. Every effort should be made to fix the ends as close as possible.



Field Joint Kits

- Each supplied joint kit contains the required number of plies of glass according to the manufacturer specifications.
- Each layer consists of one or more sections to make up the complete layers around the pipe circumference.
- These sections are pre-cut to a specific length that can be handled easily.
- Re-check the applicable layers configuration from the process sheets provided.
- The total number of plies are divided into the layers with the same number of plies & that each layer begins & ends with chopped mat plies.

Lamination on the Pipe Joint

The joints are made by wetting out the glass plies with catalyzed resin in the following manner:

- Prepare enough resin for approximately 20–30 minutes gel time by adding proper amount of catalyst in the one gallon half cut plastic pot.
- Mix the catalyzed resin with mixing tongue to make it homogenous.
- Cover the table with heavy craft paper and spread a thin layer of mixed resin on the paper over an area large enough to include the largest piece of chopped mat.

- Lay a piece of glass on the applied layer of resin on the table.
- Dip the paint woolly roller into the resin (not very deeply) and apply it on the laid mat smoothly all over the surface to wet-out well.
- Apply the second layer of glass over the previous one and wet it completely with resin using the paint roller.
- Continue building up by layers of glass and wetting out each one before applying the next one.
- Too many plies may not allow proper heat dissipation when the resin is curing and could cause blistering.
- Apply a coating of catalyzed resin directly on the pipe joint ends with the same paint roller used for wetting-out.
- Lift these resin impregnated plies with mixing stick from any corner and place them at the pipe joint which is already ground and well cleaned.
- Make sure that the wet plies are placed centered and equally distributed on the pipe ends and the first chopped strand mat lies directly on the pipe.
- Roll out the paint roller over the plies to release big air cavities and any excessive resin.
- Use steel grooved roller slightly pressed to remove the air bubbles. The angle of groove roller should be changed from time to time in order to remove the air bubbles in all directions.

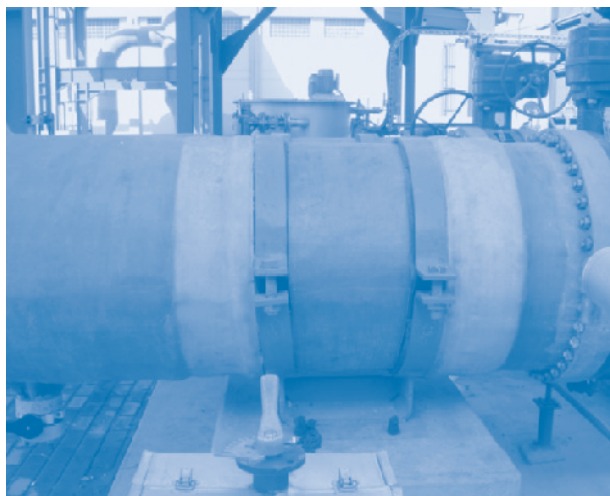

- Keeping in consideration that very limited time is left before the resin starts to gel, make sure all air bubbles have been taken out prior to the plies starting to become hard.
- Stop rolling as soon as the resin starts to gel.
- Continue this procedure until all the sections of the first layer have been applied.
- Make sure that each section overlaps with the other by minimum 50 mm.
- Allow this lay-up round to cure and cool (until it is comfortable to touch with the bare hands) prior to applying another round of plies.
- Complete the supplied number of plies application with the same procedure.
- ! **Note:** There could be another alternative to prepare the lay-up in place of on work table:
 - It is to wet out the plies directly on the pipe joint itself one by one.
 - Spread a thin layer of resin directly on the pipe joint surface.
 - Place the glass layer on the pipe joint with equal length both sides.
 - Wet out the layer through paint roller.
 - Continue in the same manner as described earlier.
- When working on the top section internally, a faster curing time is advisable. Increase slightly the amount of catalyst with a limit so that the bubble out process may end before gelling starts.
- For internal lamination, the plies edges should be penetrated into the previously made grooves on both sides of the lay-up width to maintain a smooth flow of the product during operation.
- Once the joint lamination is done, all tools should be cleaned for re-use.

Caution!

- Do not use resin if it is near to gel.
- Never allow solvent to run on un-cured resin (the layers lose bonding strength if solvent gets mixed with it).
- During periods of rapidly changing temperature, pipes may move due to expansion / contraction. This could affect the bonding strength of the initial laminations plies if these are not cured prior to movement. In such cases, the pipe should be restrained against movement while the jointing is in progress.
- Each section of the pipe should be laminated (at least partially) before another length of pipe is added. This is to avoid the excessive distances to move internally with laminated materials.
- In case the lay-up joint is not completed by the end of the day, or the layers have been given several hours to restart, the following action should be taken:
 - Remove the shiny surface of the lay-up by minor grinding.
 - Wipe the grinded area with clean solvent to remove the collected dust and allow the solvent to evaporate.
 - If the top layer of mat has been removed through grinding, an additional piece of mat should be placed.

Safety Precaution

The chemical components required for the butt-strap joints present certain safety and health hazards if not handled well. Following are the recommendations:

HAZARDS

- **Resin:** Liquid resin contains styrene which is flammable. Its vapours may cause irritation of the eyes, nose and throat. Excessive inhalation may cause dizziness, drowsiness or loss of consciousness.
- **Catalyst:** Methyl ethyl ketone peroxide is a strong oxidizing agent and is a fire and explosion hazard. It is an irritant to eyes, skin and mucous membranes, and is known as a sensitizer. It should always be stored in original containers and only a small quantity should be taken to the work place as per site activities / requirement.

- **Solvent** (AP-62 or methylene chloride): the principal hazard is loss of consciousness in case of excessive inhalation of vapours. Exposure to high vapour concentration may cause cardiac irregularities.

Precautionary Measures

- Work in adequate ventilation. Wear dust / vapour mask while mainly working inside the pipes.
- All crew members should use protective / safety glasses and rubber gloves.
- Long sleeved shirts, long trousers and hats of some kinds (depend on client safety requirement) are recommended.
- "NO SMOKING" signs must be displayed in all lamination material storage and working areas.
- All materials and chemicals should be away from heat source, sparks and open flames.

First-Aid Procedure

In case of:

- **Inhalation:** Remove the victim to fresh air.
- **Eyes:** Flush exposed eye with large amounts of flowing water. In severe cases, immediately obtain medical aid from the nearest hospital.
- **Skin:** Wash skin with soap using plenty of water.

Appendix B

Mechanical Repair (Couplings, Saddles, Sleeves)

01

02

03

04

05

06

07

app. A

app. B

app. C

Flexible Steel Couplings

(Straub, Tee Kay, Arpol, etc. - See **Figure A**)

When connecting the pipe to other pipe materials with different outside diameters, flexible steel couplings are one of the preferred joining methods. These couplings consist of a steel mantle with an interior rubber-sealing sleeve. They may also be used to join GRP pipe sections together, for example in a repair or for closure.

Three grades are commonly available:

- Coated steel mantle
- Stainless steel mantle
- Hot dip galvanized steel mantle

Control of the bolting torque of flexible steel couplings is important. Do not over torque as this may over stress the bolts or the pipe. Follow the coupling manufacturer's recommended assembly instructions for use with flexible pipe.

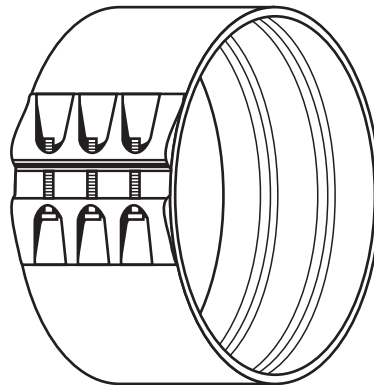

Figure A: Flexible Steel Coupling

Mechanical Steel Couplings

(Viking Johnson, Helden, Kamflex, Smith-Blair, etc. - See **Figure B**)

Mechanical couplings have been used successfully to join pipes of different materials and diameters, and to adapt to flange outlets. There is a wide variation in the design of these couplings, including bolt size, number of bolts and gasket design. Large variations also exist in the diameter tolerance of other materials, which often results in higher bolt torque than necessary in order to achieve a tight seal on the GRP side.

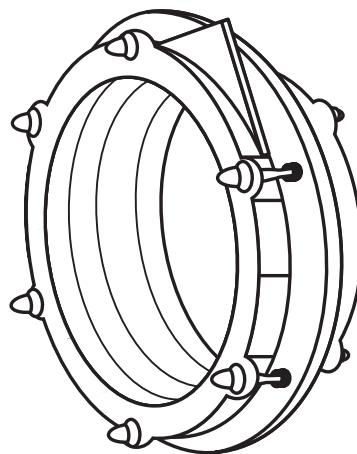

Figure B: Dual Bolt Mechanical Coupling

Mechanical Tapping and Service Sleeves

(Smith-Blair, etc. - See **Figure C**)

When performing a hot tap on an existing GRP pipe, the use of a mechanical tapping sleeve (Figure C) is one of the preferred methods of connection. Likewise, mechanical service sleeves may be utilized when the need to tap a GRP pipe becomes necessary. These sleeves consist of a steel mantle with an interior rubber-sealing sleeve.

Control of the bolting torque of mechanical tapping and service sleeves is important. Do not over torque as this may over stress the bolts or the pipe. Follow the sleeve manufacturer's recommended assembly instructions for use with flexible pipe.

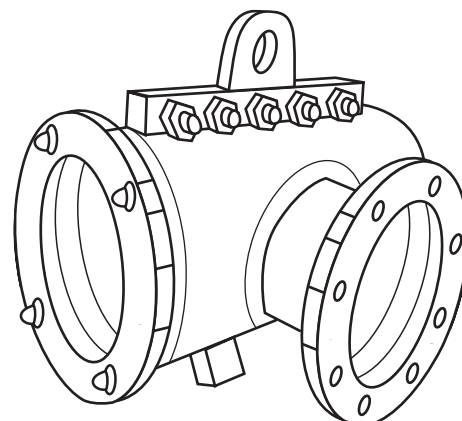

Figure C: Dual Bolt Mechanical Coupling

Appendix C

Pipe wall Liner Repair

All repairs should be on a ground surface. By repairing with glass-fiber mats the patches shall have square edges and be rectangular in shape. Overlapping areas at ends of each lay-up should be neat and tapered smooth. Lay-up thickness should be equal to the removed pipe thickness.

Procedure No. 1 To be used for repair of cracks, crazes, wrinkles, indentations, blisters, band impressions, dry areas, encapsulated materials, large white spots, missing liner and skin, etc.

- Grind away the defect and grind the laminate surface 50mm beyond the defect.
- Cut mat patches needed for the repair.
- Wet out the ground surface with polyester resin (curing agents added) and build up the laminate. Do not apply resin outside the ground area.
- Use aluminium roller to wet out the fibres and remove entrapped air. Rolling should be performed for every mat layer.
- Finish the lay-up with a surface mat.
- Cure the laminate at room temperature, or better at raised temperature using, for example, an IR oven.

Procedure No. 2 To be used for repair of surface pits, surface voids, protruded fibers, resin lumps, surface scrapes, missing or wrinkled surface mat, small white spots, etc.

- Grind the laminate surface with defects and 50 mm beyond the defects.
- Cut surface mat needed for the repair.
- Wet out the ground surface with polyester resin (curing agents added), cover the ground area with surface mat and wet out with resin.
- Cure the surface layer at room temperature, or better at raised temperature using, for example, an IR oven.

Procedure No. 3

• Weeping

Wet surface or drops of water at the exterior pipe surface detected during hydro testing at the plant. Generally weeping appears over a substantial area rather than a specific individual point. Visible dark spots or areas during standard hydro testing procedure are also classified as weeping.

• Leak

Any other loss of water during hydro testing at the plant.

• Actions and methods

If the weeping or leaking area is concentrated, consider cutting away this part and re-testing the remaining pipe(s).

Procedure No. 4 To be used for repair of internal surface delamination in interior surface mat and liner. Samples of such de-laminations are rip-offs caused by the saw or rough handling of the pipe.

Evaluate degree of delamination.

- Damage is in the interior surface mat:
 - Grind away the delaminated area.
 - Remove dust.
 - Coat the ground surface with resin.
- Damage is deep into the liner:
 - Grind the pipe surface beyond the delaminated area
 - Remove dust from the surface.
 - Wet out the ground surface with resin.
 - Apply 1 layer of 450g/m² chopped strand mat.
 - Coat with resin.
 - After curing, grind off excess material and protruding fibres.

Procedure No. 5 To be used for repair of local outside damage going down into the outer skin.

- Grind away the damaged part of the laminate.
- Gravity pipe.
 - Grind the pipe surface beyond the damaged part in all directions.
 - Wet out the ground surface with resin and build up a laminate to fill the groove, with chop mat plus woven roving or combine. Start with a chop mat and alternate with woven roving plies. When the groove is filled, continue the lamination extending it to cover all of the ground surface. The laminate should have a thickness according to the manufacturers guidelines and be tapered to pipe wall over a distance of 4 times the thickness of the overlapping laminate.
 - The first and the last ply in the lamination should be a chop mat.
- Pressure pipe
 - Grind the pipe surface on both sides of the damaged spot in the axial direction, and all around the circumference of the pipe.
 - Remove dust from the surface.
 - Wet out the ground area with resin just prior to application of the first ply of mat.
 - Build up a laminate to fill the groove of the damaged spot with chop mat plus woven roving or combine. Start with a chop mat and alternate with woven roving plies.
 - When the groove is filled, continue the lamination and extend it to cover all of the ground surface. The laminate should have a thickness according to the manufacturers guidelines, and be tapered to pipe wall over a distance of 4 times the thickness of the overlapping laminate.
 - Finish the lamination with a surface veil.

This Maintenance Manual is the intellectual property of FTEC. All rights reserved. No part of this Maintenance Manual may be reproduced, stored in a retrieval system, or transmitted in any form or by any means, electronic, mechanical, photocopying, recording or otherwise without the prior permission of the intellectual property owner.

This handbook is intended as a guide only. All values listed in the product specifications are nominal. Unsatisfactory product results may occur due to environmental fluctuations, variations in operating procedures, or interpolation of data. We highly recommend that any personnel using this data have specialised training and experience in the application of these products and their normal installation and operating conditions.

The engineering staff should always be consulted before any of these products are installed to ensure the suitability of the products for their intended purpose and applications. We hereby state that we do not accept any liability, and will not be held liable, for any losses or damage which may result from the installation or use of any products listed in this handbook as we have not determined the degree of care required for product installation or service. We reserve the right to revise this data, as necessary, without notice. We welcome comments regarding this handbook.